

Servo-motor controlled Flow Control Valve NG 6 ISO 4401

Operation pressure 150 bar

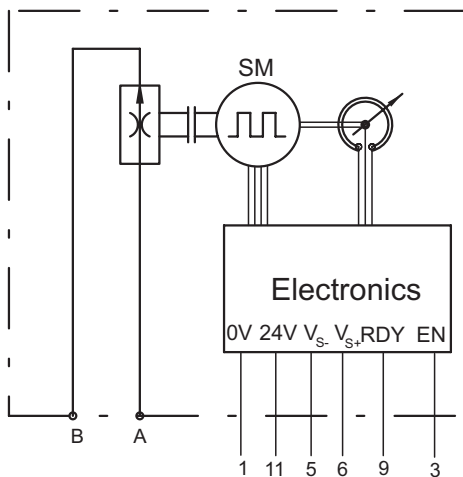

Symbol:



Connector 17 pol:

1 0V	≧	Supply 24V/1A
11 24V		
5 V _{S-}	≧	Set value 0...10V
6 V _{S+}		
9 RDY	—	Status output:
3 ENABLE	—	Release

Rate of flow:

Flow Q _{max} (cm ³ /min)	Rate of flow
100	0.1
200	0.2
400	0.4
500	0.5
1200	1.2
1500	1.5
3000	3.0
6000	6.0
8000	8.0
9000	9.0
20000	20.0

- Reproducibility even with low flow rates, up to 5 cm³/min
- Fluid flow can be controlled nearly independently of pressure and viscosity
- Control range from 0,075% to 100% adjustment
- Electrical position feedback
- Integrated electronics (digital or analog drive)

Specifications according to VDI 3267

General

Configuration number	see symbol
Type	gap-type throttle valve
Fastening	2x M5x40 DIN912
Connection of ports	mounting plate
Mounting position	mountable in any position
Ambient temperature °C	-5 bis +50
Mass of valve kg	3,0
Mass of mounting plate kg	1,0

Hydraulic

Operation pressure	
Ports A, B	bar 150
Hydraulic oil temperature °C	-10 bis +70
Viscosity range mm ² /s	10 bis 300
max. rate of flow l/min	20
Operation	electrically
Angle of rotation	300°

Electrical

Electric power supply	
Without break	24V DC; 0,3A- 0,6A
With break	24V DC; 0,8A- 1,1A
Allowed command value	
Analog	0...10V
Adjusting time	200 ms at 100% displacement

Options:

- Electric break

The specifications given herein are subject to alteration

Servo-motor controlled Flow Control Valve NG 6 ISO 4401

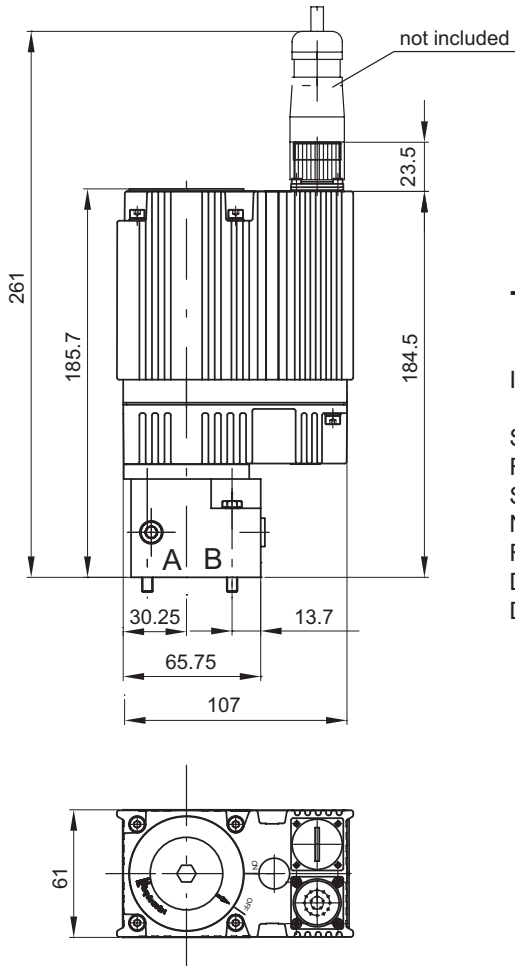

Type code:

Ident.-Nr.

Servo-motor controlled
Flow control valve
Symbol
Nominal size
Flow range
Design
Design code

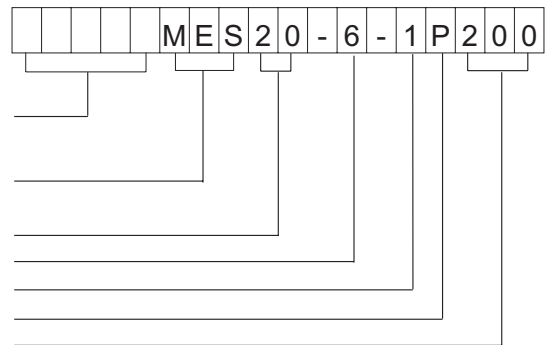

Port connection pattern

Nominal size NG6 ISO 4401
The figure shows the side of the mounting plate to which the valve is fastened.

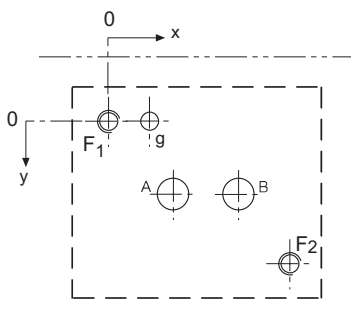

Single-unit mounting plate

order number:
PM6-G1-400 R 1/8"
PM6-G2-400 R 1/4"
PM6-G3-400 R 3/8"

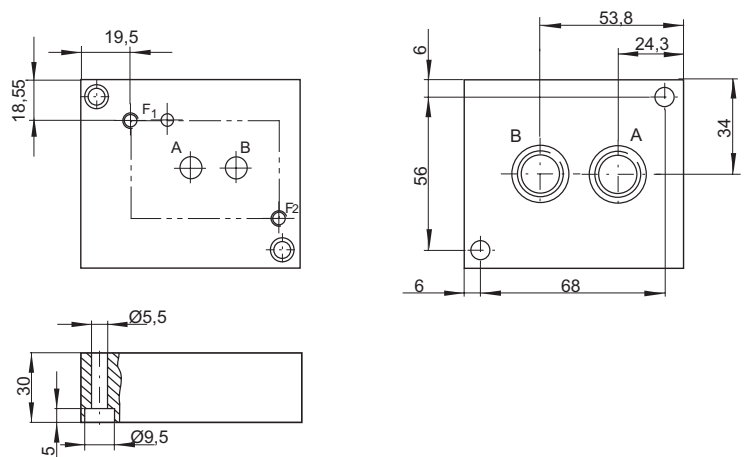

	A	B	g	F1	F2
Ømax	Ø7	Ø7	Ø3,5	M5	M5
x	12,7	30,2	7,5	0	40,5
y	15,5	15,5	0	0	31,75

The specifications given herein are subject to alteration